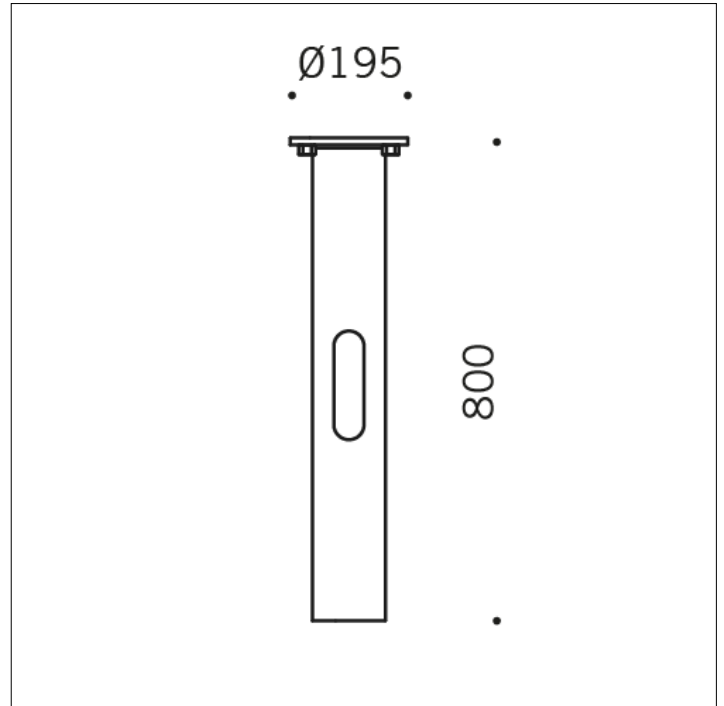

ACCESSOIRE

**S.4129**
EMBASE DE FIXATION

Embase $\text{Ø} 195$ mm h 800 mm à cémenter au sol avec vis en acier INOX.