

















S I M E S

# MICROLED

ISTRUZIONI DI MONTAGGIO, USO, MANUTENZIONE E SMALTIMENTO  
INSTALLATION, USE AND MAINTENANCE AND WASTE MANAGEMENT INSTRUCTIONS

<b>MICROLED</b>		     			
ARTICOLO ARTICLE	CLASSE CLASS SCHUTZKLASSE CLASSE Klasse Класс SUOJAUUSLUOKKA CLASSE	Lampada	Lamp	Ljuskälla	VETRO GLASS VERRE  T(°C)
		Lamp	Lampe	Lampe	Светильника Lampputyyppi Lämpada
		Lámpara	Lämpada	Lämpada	Ta 25°C
S.3334.19	III 	LED RGB	24V	1,3W 	39° C 
S.3335.19	III 	LED BIANCO/WHITE	24V	1W 	39° C 
S.3335W.19	III 	LED BIANCO/WHITE	24V	1W 	39° C 

S.3334.19  
S.3335.19  
S.3335W.19

Fornito con cavo  
Supplied with cable  
L 1m

**CASSAFORMA**  
**RECESS BOX**

2X

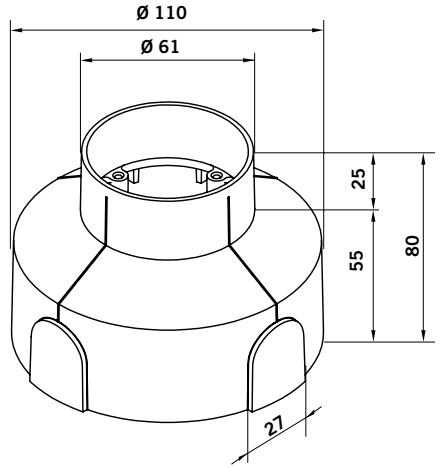
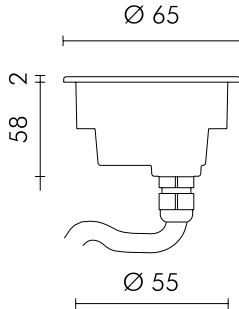
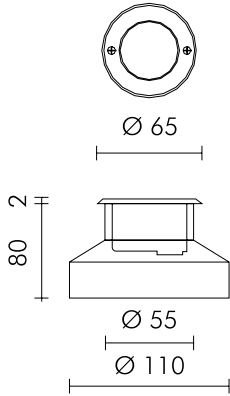

**I OGNI MODIFICA DELL'APPARECCHIO E' PROIBITA SENZA PREVIA AUTORIZZAZIONE !!**

La sicurezza dell'apparecchio è garantita solo rispettando le normative europee del settore elettrico e le istruzioni contenute in questa scatola; pertanto è necessario conservarle. Il rispetto di queste istruzioni è fondamentale per il corretto funzionamento dell'apparecchio e dell'impianto.

L'installazione deve essere fatta da personale qualificato.

Togliere tensione prima di eseguire le operazioni di manutenzione.

Nel caso di danneggiamento del cavo fornito il prodotto deve essere distrutto.

Per l'installazione utilizzare le apposite scatole da incasso. Installabile anche a parete e a soffitto.

**GB ANY MODIFICATION TO THIS FITTING IS FORBIDDEN WITHOUT AUTHORIZATION !!**

The safety of the fitting is guaranteed only respecting the electrical European norms and the mounting instructions in this box; therefore it is important to conserve them. The respect of these instructions is very important for the fitting and the main line life.

Installation should be carried out by a suitable qualified person in accordance with good electrical practice and the appropriate national wiring regulations.

Disconnect main voltage before maintenance operations.

In case of damage of the supplied cable the fitting must be destroyed.

It is necessary use the appropriate recess box for recess. Wall recessed or Downlight applications allowed.

**D JEDE UNBEFUGTE ÄNDERUNG AN DIESER LEUCHE IST VERBOTEN !!**

Die Sicherheit der Leuchte ist nur bei Einhaltung der europäischen Normen und der in dieser Packung enthaltenen Montageanleitungen gewährleistet. Diese sind daher sorgfältig aufzubewahren.

Diese Anweisungen sind daher unbedingt einzuhalten, um die Funktionsfähigkeit dieser Leuchte und der Beleuchtungsanlage sicherzustellen. Bitte sorgfältig aufbewahren.

Diese Leuchte muss fachmännisch installiert werden.

Vor Wartungsarbeiten die Leuchte vom Netz trennen.

Im Fall die Verletzung des Kabels den Produkt muss zerstört sein.

Für die Installation brauchen Sie die bestimmte Eibaugehäuse, wenn sie noting sind.

**F TOUTE MODIFICATION DE CET APPAREIL, SANS AUTORISATION, EST INTERDITE !!**

La sécurité des appareils est garantie uniquement en respectant les normes électriques européennes et les instructions contenues dans l'emballage; aussi est-il nécessaire de les conserver. Le respect de ces instructions est fondamental pour un fonctionnement correct de l'appareil et de l'implantation électrique et doit être suivi scrupuleusement.

L'installation doit être effectuée par des personnes qualifiés.

Couper l'alimentation avant d'exécuter toute manutention.

En cas de endommagement du cable il faut détruire le produit.

Pour l'installation, s'ils sont prévu, utiliser les boîtes d'encastrement spéciales.

**E CUALQUIER MODIFICACION DE LOS APARATOS ESTA PROHIBIDA SIN AUTORIZACION !!**

La seguridad de los aparatos está garantizada solamente respetando las normas eléctricas Europeas y las instrucciones de montaje incluidas en la caja, por lo tanto es importante conservarlas. El respeto de estas instrucciones es fundamental para el correcto funcionamiento del aparato y de la instalación.

La instalación debe hacerla personal calificado.

Desconectar la alimentación principal antes de continuar las operaciones de mantenimiento.

In case of damage of the supplied cable the fitting must be destroyed.

It is necessary use the appropriate recess box for recess. Wall recessed or Downlight applications allowed.

**SE ALL OMBYGGNAD AV DENNA ARMATUR ÄR FÖRBJUDEN !!**

Säkerheten av och garantin för armaturen gäller endast om man följer det Europeiska elektriska normerna samt följer den till armaturen bifogade monteringsanvisningen; därför är det viktigt att spara den. Installation får endast utföras av behörig person i enlighet med god elektrisk installationssed och nationella installationsregler.

Koppla från armaturen före allt underhåll.

In case of damage of the supplied cable the fitting must be destroyed.

It is necessary use the appropriate recess box for recess. Wall recessed or Downlight applications allowed.

**NL ALLE NIET VOORAF TOEGESTANE WIJZIGINGEN AAN DIT TOESTEL ZIJN VERBODEN !!**

Uitsluitend op basis van de geldende Europeesche normen, en de montagehandleiding in deze doos kunnen wij de veiligheid van de armatuur garanderen. Het is daarvoor van belang deze goed te bewaren. Het respecteren van deze instructies is van belang voor de levensduur van de installatie.

De installatie moet worden uitgevoerd door een goed gekwalificeerd persoon met de juiste opleiding, en op basis van de nationale regelgeving m.b.t. bedraden.

Sluit de voedingsspanning af voor onderhoud.

In case of damage of the supplied cable the fitting must be destroyed.

It is necessary use the appropriate recess box for recess. Wall recessed or Downlight applications allowed.

**RU ЛЮБЫЕ ИЗМЕНЕНИЯ КОНСТРУКЦИИ СВЕТИЛЬНИКА БЕЗ СОГЛАСОВАНИЯ ЗАПРЕЩАЮТСЯ !!**

Безопасность светильника гарантирована только при соблюдении электрических норм и правил (ПУЭ), а также инструкции по установке светильника, которая находится в коробке. Поэтому очень важно сохранить их.

Установка должна осуществляться квалифицированным электриком, имеющим опыт установки подобного оборудования, а также имеющим соответствующий допуск к работам.

Не используйте источники света мощностью выше обозначенной.

In case of damage of the supplied cable the fitting must be destroyed.

It is necessary use the appropriate recess box for recess. Wall recessed or Downlight applications allowed.

**FI KAIKENLAISET VALAISIMEN MUUTOSTYÖT ILMAN VALMISTAJAN SUOSTUMUSTA OVAT KIELLETTYJÄ !!**

Valaisimen käyttöturvallisuutta ei taata, mikäli valaisinta ei ole asennettu pakkauksessa tulleiden ohjeiden mukaisesti ja käytetty Eurooppalaisten normien mukaisesti; näin ollen on tärkeää säilyttää nämä ohjeet.

Valaisimen ja syöttökaapelin käyttöikää ajatellen näiden ohjeiden noudattaminen on ensiarvoisen tärkeää. Asennustyö on suoritettava valtuutetun sähköasentajan toimesta.

Katkaise pääjännitte huoltotöiden ajaksi.

In case of damage of the supplied cable the fitting must be destroyed.

It is necessary use the appropriate recess box for recess. Wall recessed or Downlight applications allowed.

**P QUALQUER ALTERAÇÃO NESTE APARELHO, SEM AUTORIZAÇÃO, É INTERDITA !!**

A segurança das luminárias é garantida somente se as normas eléctricas Europeias forem respeitadas bem como as instruções de montagem que estão na embalagem. É necessário conservá-las após montagem. A observação das instruções é fundamental para um funcionamento correcto da mesma e a ligação eléctrica deve ser seguida escrupulosamente.

A instalação deve ser executada só por pessoal qualificado.

Cortar a alimentação antes de executar a manutenção.

In case of damage of the supplied cable the fitting must be destroyed.

It is necessary use the appropriate recess box for recess. Wall recessed or Downlight applications allowed.

- I Nel caso in cui SIMES S.p.A. dia il consenso al reso di apparecchi per il controllo, essi dovranno essere resi senza essere smontati (aprire solo l'anello superiore per la rimozione dalla cassaforma, ove necessario). La scatola di cablaggio NON DEVE essere aperta; il pressacavo non deve essere toccato; deve essere lasciato un pezzo di cavo di alimentazione di 10-20 cm. uscente dalla scatola di cablaggio.
- N.B.** L'apparecchio IP67 è stagno all'immersione secondo la norma CEI EN 60598-1. La prova di laboratorio prevede che l'apparecchio sia spento e subito dopo immerso per 30 min. in modo che la parte superiore sia almeno 150 mm sotto il livello dell'acqua e la parte inferiore almeno 1 metro. L'apparecchio deve essere mantenuto in posizione dai suoi mezzi di fissaggio normale. Gli apparecchi per lampade fluorescenti tubolari devono essere posizionati orizzontalmente, con il diffusore rivolto verso l'alto, almeno 1 metro sotto il livello dell'acqua.
- GB If SIMES S.p.A. agrees to receive back some fittings for laboratory testing, they **MUST NOT BE DISASSEMBLED**. If necessary remove only the upper ring, to remove the fitting from its recessing box. The connection box, where the wiring to the terminal block is done, must not be opened and you must cut the cable around 10-20 cm from the connection box.
- NOTES:** The fitting IP67 is watertight, according to CEI EN 60598-1 norms. In the laboratory test the fitting is switched off and immediately immersed in water for 30 min., with the upper part at least 150 mm below the water level and the bottom part at least 1 meter. The fitting must be placed in its working position by its standard fixing system. Fittings for tubular fluorescent lamps must be placed horizontally, looking upwards, 1 meter below the water level.
- D Wenn SIMES S.p.A. der Rücksendung von Leuchten zwecks Prüfung zustimmt, diese bitte vorher nicht zerlegen. Wenn nötig, nur den oberen Ring entfernen, um die Leuchte aus dem Einbaugehäuse zu nehmen. Nicht den Anschlusskasten und die Verschraubung öffnen, das Kabel in 10-20 cm Abstand von der Anschlussdose durchtrennen.
- ACHTUNG:** Diese Leuchte in der Schutzart IP67 ist wasserdicht gemäß CEI EN 60598-1. Im Labortest wird die Leuchte abgeschaltet und unmittelbar danach 30 Minuten lang in Wasser eingetaucht, wobei sich die Oberseite der Leuchte mindestens 150 mm, die Unterseite mindestens 1 m unterhalb der Wasseroberfläche befindet. Die Leuchte muss dabei mit den üblichen Befestigungsmitteln in normaler Betriebslage gehalten werden. Leuchten für röhrenförmige Leuchtstofflampen müssen mit der Abdeckung nach oben 1 m unter der Wasseroberfläche stehen.
- F Dans le cas où SIMES S.p.a donne son accord pour un retour d'appareils afin d'en effectuer le contrôle, ceux-ci devront être rendus sans être démontés (ouvrir uniquement la collerette supérieure pour le désolidariser du boîtier d'encastrement, si nécessaire). La boîte de câblage ne DOIT PAS être ouverte, le presse-étoupe ne doit pas être touché ; il faut laisser, à la sortie de la boîte de câblage, un morceau de câble d'alimentation de 10 à 20 cm.
- N.B.** L'appareil IP 67 est étanche à l'immersion selon la norme CEI EN 60598-1. Les tests de laboratoire prévoient que l'appareil soit éteint ,et immergé tout de suite après pendant 30 min, de façon à ce que la partie supérieure soit sous le niveau de l'eau d'au moins 150 mm, et la partie inférieure d'au moins 1 m. L'appareil doit être maintenu en position par les moyens de fixation normaux. Les appareils pour lampes fluorescentes tubulaires doivent être positionnés horizontalement, avec le diffuseur positionné vers le haut, au moins 1 m sous le niveau de l'eau.
- E En el caso que SIMES S.p.A. deba analizar algún aparato , deberá entregarse sólo el aro superior. La caja de cableado NO DEBE ABRIRSE; el prensa no debe tocarse y debe dejarse un cable de 10-20cm saliendo de la caja de cableado.
- NOTA:** Los aparatos IP67 son estancos a la inmersión según la norma CEI EN 60598-1. En el laboratorio de pruebas se sumerge durante 30 min, con la parte de arriba al menos 150mm debajo el nivel del agua y la parte de abajo al menos 1 mts. El aparato se mantiene en su posición standard. Los aparatos con lámpara fluorescente deben colocarse horizontalmente, con el difusor hacia arriba, al menos 1mts bajo el nivel del agua.

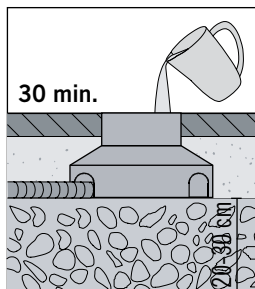

I Predisporre sempre 20-30 cm di ghiaia sotto il pozzetto, poi riempirlo di acqua e assicurarsi che esca tutta entro 30 min. In caso contrario è obbligatorio un sistema di drenaggio supplementare (Fig. A).

GB Prepare always 20-30 cm of drainage gravel and check that it works: fill the tube of water and check that it completely disappear within 30 min. If it doesn't work study a further drainage system (Fig. A).

D Immer 20-30 cm Dränagekies unterhalb des Erdeinbaugeschäuses platzieren und die Funktionstüchtigkeit überprüfen: Das mit Wasser gefüllte Gehäuse muss sich innerhalb von 30 Minuten leeren. Andernfalls ist ein zusätzliches Dränagesystem notwendig.

F Prédisposer toujours 20-30 cm de gravier sous le puits et le remplir d'eau et s'assurer que celle-ci se soit toute écoulée en 3 min. Dans le cas contraire, un drainage supplémentaire est obligatoire (Fig. A).

E Preparar siempre 20-30cms de grava de drenaje debajo la hornacina, llenar de agua y comprobar que en 30 min desaparezca. Si no va bien hacer un sistema de drenaje complementario.(Fig A).

SE Dränera alltid 20-30 cm och se till att det fungerar genom att fylla tuben med vatten och kontrollera att vattnet runnit ut efter 30 minuter. Om det inte fungerar, använd då en alternativ dränering. (se fig. A)

NL Zorg steeds voor een grindlaag van 30 cm, of eender welk equivalent drainagesysteem en controleer de werking ervan. Giet de inbouwdoos vol water en controleer of dit water binnen de 30 minuten ook verdwijnt. Is dit niet zo, dan dienen bijkomende drainagewerken te worden uitgevoerd (Fig. A).

RU Перед установкой подготовьте дренажную систему из гравия (20-30 см) и проверьте, работает ли она: заполните трубу водой и проверьте, исчезла ли она полностью в течение 30 мин. Если этого не произошло, проверьте дренажную систему. (Fig.A).

FI Valaisimen upotuskotelon alle tulee asentaa 20-30 cm kerros salaajosoraa. Mikäli vedellä täytetty upotuskotelo ei tyhjene täysin 30 min. kuluessa on upotuskotelo salaajittettava esim. kuvan A mukaisella tavalla.

P Prever sempre 20 a 30 cms de gravalha para drenagem por baixo do negativo, para assegurar um bom escoamento em 30 minutos, caso contrário é necessário um escoamento suplementar (Fig.A).

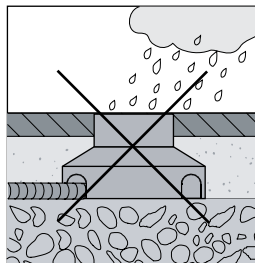
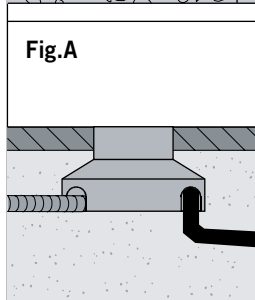

I Non installare mai il prodotto in caso di pioggia, nebbia o forte umidità.

GB Never install the fittings in case of rain, fog or high humidity.

D Die Leuchte nicht bei Regen, Nebel oder starker Feuchtigkeit installieren.

F Ne jamais installer les appareils en cas de pluie, brouillard, ou forte humidité.

E Nunca instalar los aparatos en caso de lluvia, niebla o alta humedad.

SE Installera aldrig armaturen om det regnar, är dimmig eller hög luftfuktighet.

NL Het is verboden de toestellen te plaatsen bij vochtige omstandigheden (mist, regen, hoge luchtvochtigheid).

RU Никогда не устанавливайте светильники в условиях дождя, тумана или повышенной влажности.

FI Älä asenna valaisinta sateessa, sumussa tai kun ilman kosteus on huomattavan korkea.

P Nunca montar as luminárias quando: Chova, em caso de nevoeiro ou grande humidade.

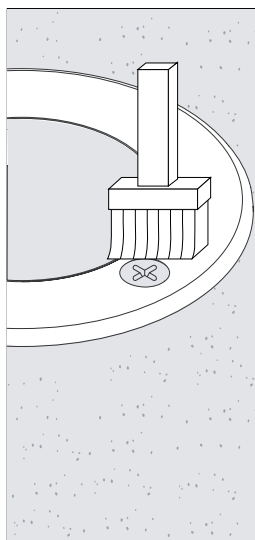

I Pulire periodicamente gli apparecchi per rimuovere gli accumuli di sporco che si deposita sulle griglie e nella testa delle viti.

GB Periodically clean the fittings in order to remove possible soil heap on cages or screw heads.

D Die Leuchte regelmäßig säubern, um Schmutzablagerungen auf Rastern und Schraubenköpfen zu entfernen.

F Nettoyer périodiquement les appareils afin d'éliminer les résidus de terre qui se déposent sur les grilles et les têtes des vis.

E Abrir y cerrar los tornillos en secuencia alterna. Limpiar periódicamente las luminarias para quitar suciedad de las rejillas y de los tornillos.

SE Rengör regelbundet armaturen genom att hålla skruv och sarg fria från smuts.

NL Reinig ook op geregelde tijdstippen het toestel, zodat er zich geen vuil ophoopt rond de schroefdraad en op de schroefkoppen.

RU Время от времени протирайте светильники для того, чтобы убрать накапливающийся слой земли на поверхности светильника и болтах.

FI Puhdista valaisimen näkyvät osat ja ruuvinkannat säännöllisesti valaisimen päälle mahdollisesti kertyneestä maa-aineksesta.

P Limpar periodicamente as luminárias, afim de eliminar resíduos de terra que se depositam sobre as ranhuras e as cabeças dos parafusos embebidos.

# RACCOMANDAZIONI GENERALI INTERRATI INGROUND FITTINGS GENERAL RACCOMANDATIONS

# S I M E S

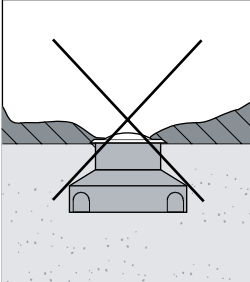
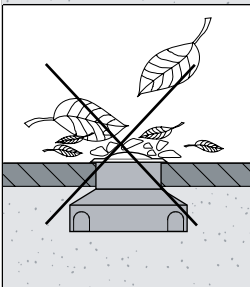
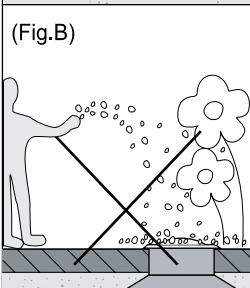
	<p>I Non ricoprire mai le parti in vista dell'apparecchio. Nessuna parte dell'apparecchio non protetta dalla cassaforma deve stare a contatto diretto con il terreno, o venire a contatto con sostanze chimiche aggressive (es. Fertilizzanti, diserbanti, calce (Fig. B)).</p> <p>GB Never cover visible parts of the fittings. Any part not protected by the recessing box, must not be in direct contact with the ground or in contact with aggressive chemical elements (ex. Fertilisers, herbicides, lime(Fig. B)).</p> <p>D Die Oberseite der Leuchte muss immer frei bleiben. Leuchtenteile, die nicht durch das Einbauegehäuse geschützt sind, dürfen nicht mit dem Erreich oder aggressiven chemischen Stoffen (z.B. Dünger, Unkrautvernichter, Kalk) in Berührung kommen.</p> <p>F Ne jamais recouvrir les parties visibles de l'appareil. Aucune partie de l'appareil non protégée par la boîte d'encastrement, ne doit être en contact direct avec le terrain, ou venir au contact de substances chimiques agressives (ex : fertilisants, herbicides, chaux (fig.B)).</p> <p>E Nunca cubrir el aparato. Cualquier parte no protegida por la caja no debe estar en contacto con el suelo, ni con elementos químicos agresivos ( fertilizantes, herbicidas, cal (Fig. B))</p> <p>SE Täck aldrig över armaturens ovansida. De delar som ej skyddas av infällnadsboxen får ej komma i direkt beröring med farliga kemikalier såsom, gödningsmedel, ogräsmedel, kalk, etc. (se fig. B)</p> <p>NL De bovenzijde van het toestel dient steeds vrij te blijven. Geen enkel deel van het toestel dat niet beschermd is door de inbouwdoos, mag in contact komen met de grond of met agressieve chemische stoffen (meststof, onkruidverdelgers, kalk ...)(Fig. B)).</p>
	<p>RU Никогда не закрывайте видимую поверхность светильника. Любая часть, незащищенная встраиваемой коробкой, не должна находиться в прямом контакте с землей или другими активными химическими элементами (например, удобрениями, гербицидами, известью и т.п.)</p> <p>FI Älä peitä valaisimen näkyviä osia. Huolehdi siitä, etteivät valaisimen osat upotuskoteloa lukuunottamatta ole suorassa kosketuksessa maa-ainekseen tai voimakkaiden kemikaalien (lannoitteet, kalkki, tms.) kanssa.</p> <p>P Nunca cubrir as partes visíveis da Luminária. Nenhuma parte da luminária não protegida pelo negativo de encastramento deve estar em contacto directo com o terreno, ou vir a ter contacto com substâncias químicas agressivas (ex: fertilizantes, herbicidas, cal (Fig.B)).</p>
<p>(Fig.B)</p> 	

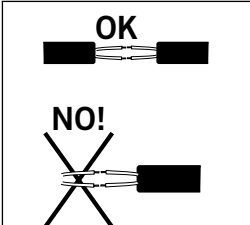
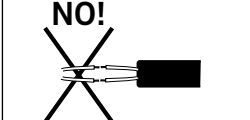
 <p>OK</p>  <p>NO!</p>	<p>I Utilizzare solo cavi di alimentazione in doppia guaina.</p> <p>GB Use only supply cables with double case.</p> <p>D Brauchen Sie nur die Speisekabel mit doppeltem Mantel.</p> <p>F Utiliser seulement cables d'alimentation avec double gaine.</p>
--	--

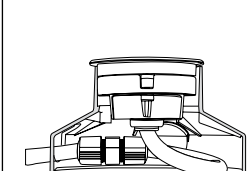
 	<p>I Il cablaggio deve essere realizzato, all'interno della cassaforma, usando il connettore IP67 S.5501 fornibile su richiesta (per tale accessorio utilizzare cavi bipolari avente sezione dei cavi 0,75-1,5mm<sup>2</sup> e diametro 5,6mm-9mm) oppure realizzare il cablaggio all'interno di una scatola di cablaggio separata.</p> <p>GB Make the wiring in the recess box using the IP67 fast connector S.5501 supplied on request (for this accessory use supply cable bipolar with section 0,75-1,5mm<sup>2</sup> and diameter 5,6mm-9mm) or make the wiring in a separate IP67 recess box.</p>
---	---



- I Usare solo cavi flessibili in gomma <HAR> di diametro adatto.  
NON USARE CAVI RIGIDI e/o CON ANIMA METALLICA  
(Cavi rigidi possono compromettere la tenuta IP67).
- GB Use only <HAR> flexible cables of suitable diameter.  
DO NOT USE HARD CABLES OR ARMORED CABLES  
(Hard cable could effect the IP67 protection).
- D Nur flexible Gummikabel <HAR> verwenden.  
KEINE STARREN LEITUNGEN VERWENDEN  
(diese können die Schutzart IP67 beeinträchtigen).
- F Utiliser uniquement des câbles souples.  
NE PAS UTILISER DE CABLES RIGIDES ou ARMES  
(Les câbles rigides peuvent compromettre l'étanchéité IP67).
- E Utilizar solo <HAR> cables flexibles.  
NO ENTRAR CON CABLES RIGIDOS o BLINDADOS  
(Cable rígido puede afectar la protección IP67).
- SE Använd endast "HAR" mjuka kablar med avsedd diameter.  
ANVÄND EJ HÅRDA ELLER ARMERADE KABLAR.  
(Armerade kablar kan inverka negativt på IP 67-skyddet.)
- NL Gebruik enkel <HAR> soepele kabels.  
GEEN VASTE OF GEWAPENDE SNOEREN GEBRUIKEN !  
(deze kunnen de IP67-graad aantasten).
- RU Используйте только гибкие кабели <HAR>.  
**Ни в коем случае не используйте жесткие или армированные кабели.**  
(Жесткий кабель не может обеспечить защиту Ip67).
- FI Käytä vain <HAR> hyväksytyä H07RN-F liitoskaapelia (VSN).  
ÄLÄ KÄYTÄ JÄYKKÄÄ TAI ARMEERATTUA KAAPELIA !  
(koska se saattaa vaikuttaa IP67t-luokitukseen).
- P Utilizar sempre cabos flexíveis.  
NUNCA UTILIZAR CABOS RÍGIDOS OU ARMADOS.  
(Os cabos rígidos podem comprometer a estanquicidade IP67).



H07RN-F

1,5 mm<sup>2</sup>

- I Apparecchio predisposto per il montaggio diretto su superfici normalmente infiammabili.
- GB Luminaire suitable for direct mounting on flammable surfaces.
- D Die Leuchte ist zur Montage auf normal entflammbaren Oberflächen geeignet.
- F Appareil prédisposé pour le montage sur des surfaces normalement inflammables.
- E Aparato preparado para ser montado directamente en superficies inflamables.
- SE Armatur kan appliceras på brännbara ytor.
- NL Armatuur geschikt voor montage op brandbare oppervlakten.
- RU светильники могут быть установлены на легковоспламеняющуюся поверхность.
- FI Valaisin voidaan asentaa normaalisti syttyvälle alustalle.
- P Luminária possível de ser instalada em superfícies normalmente inflamáveis.



- I Apparecchi calpestabili. Carico Massimo 1000 Kg.
- GB Walk over fittings. Max Load 1000 Kg.
- D Begehbare Leuchten. Max Load 1000 Kg.
- F Appareils piétonniers. Max Load 1000 Kg.
- E No pisable por vehiculos. Max Load 1000 Kg.
- SE Bewandelbare toestellen. Max Load 1000 Kg.
- NL Gångtålig armatur. Max Load 1000 Kg.
- RU Нагрузка до двухсот килограммов. Max Load 1000 Kg.
- FI Sopii jalakulkuväylälle. Max Load 1000 Kg.
- P Walk over fittings. Max Load 1000 Kg.

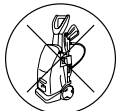
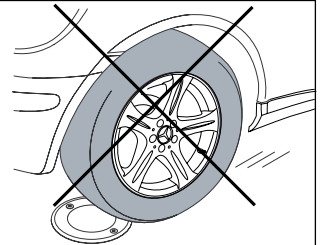

- I Non utilizzare idropulitrici.
- GB Do not use water high pressure cleaners.
- D Hochdruckreiniger benutzung ist verboten.

# SOLUTION

# A

**INSTALLAZIONE CON CASSAFORMA  
INSTALLATION WITH RECESS BOX**

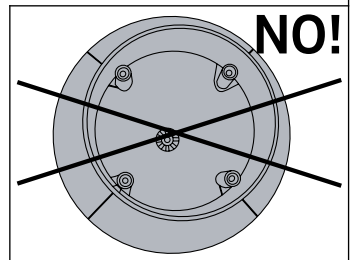
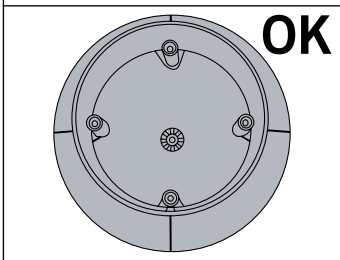
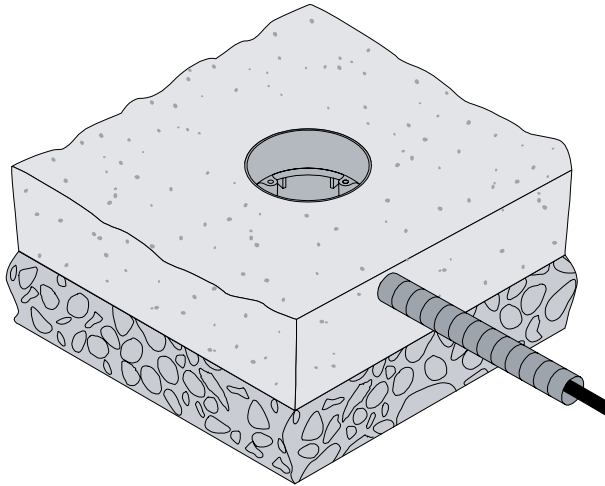
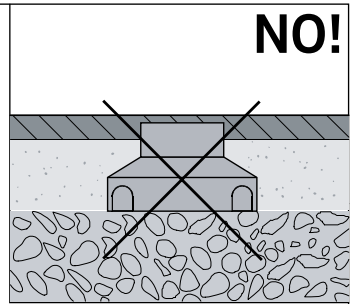
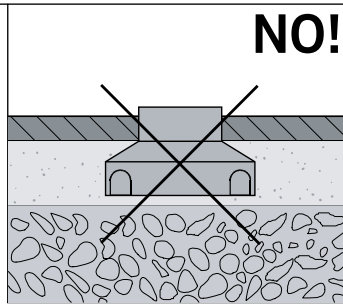
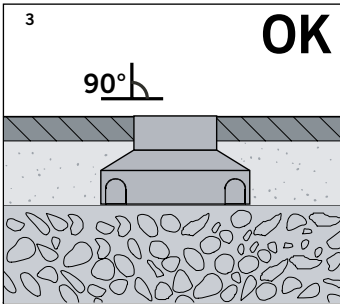
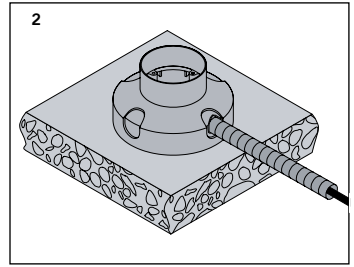
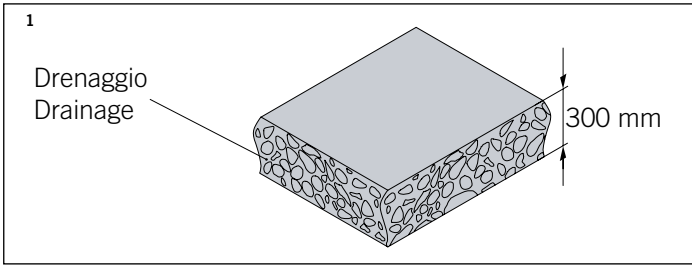

4

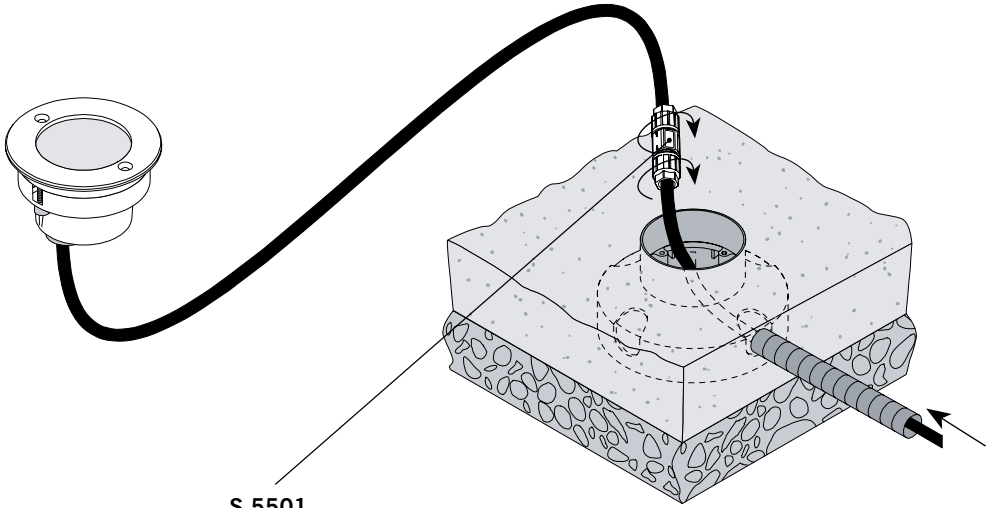

**S.5501**  
**Connettore rapido a richiesta**  
**Fast connector on request**

5

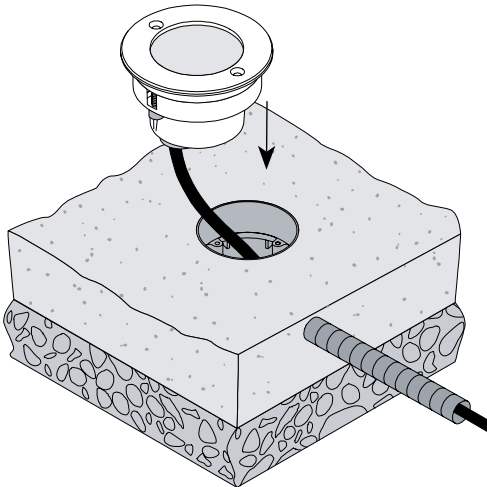

6

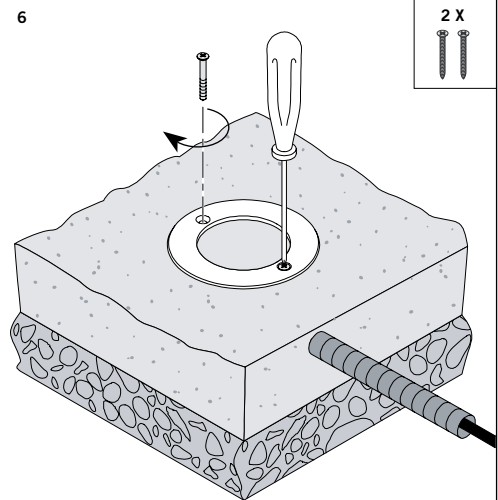

# **SOLUTION**

# **B**

**INSTALLAZIONE PER APPLICAZIONI  
A PANNELLO O SOFFITTO**

**INSTALLATION FOR  
FLOATING WALLS OR CEILING APPLICATION**

**INSTALLAZIONE PER APPLICAZIONI A PANNELLO O SOFFITTO**  
**INSTALLATION FOR FLOATING WALLS OR CEILING APPLICATION**

**S I M E S**

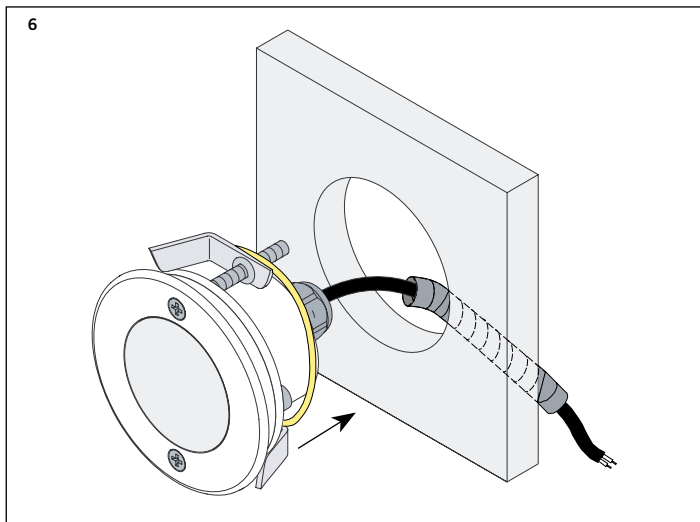
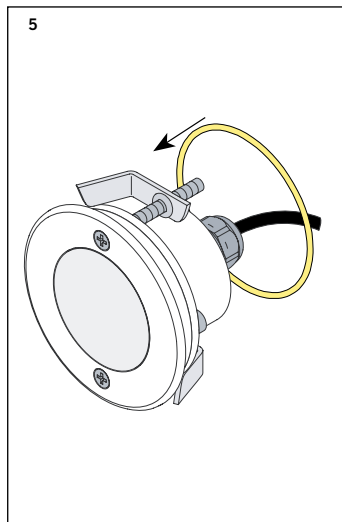
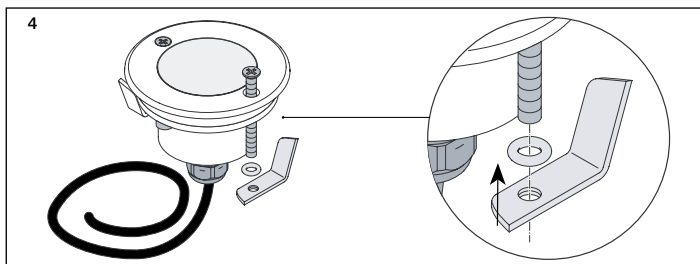
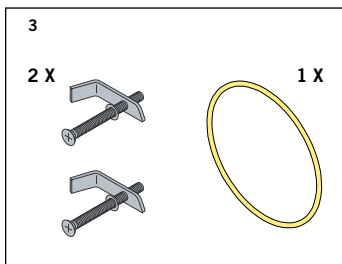
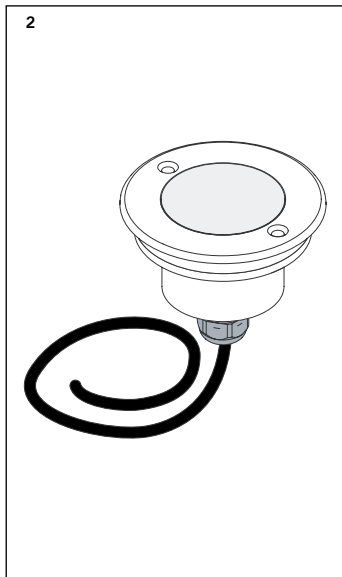
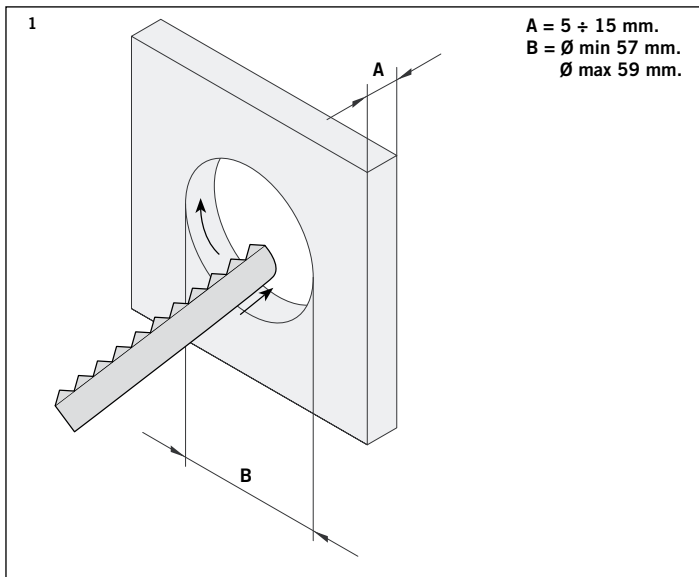

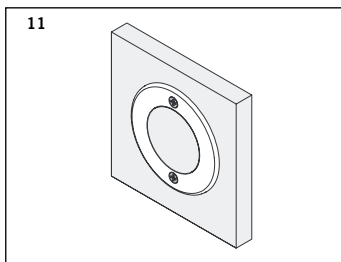
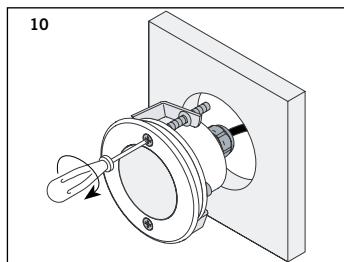
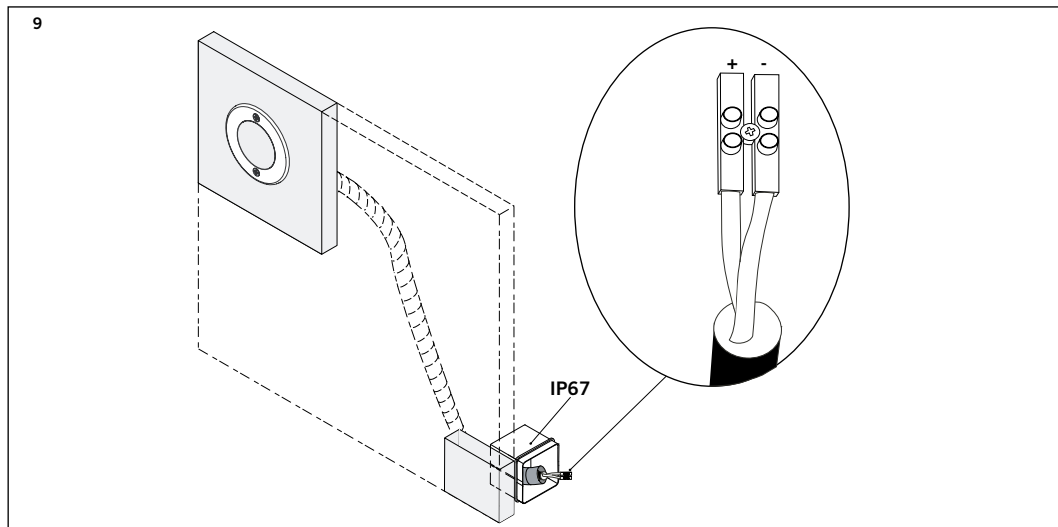
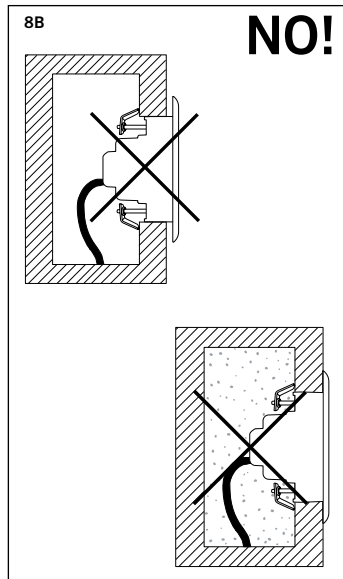
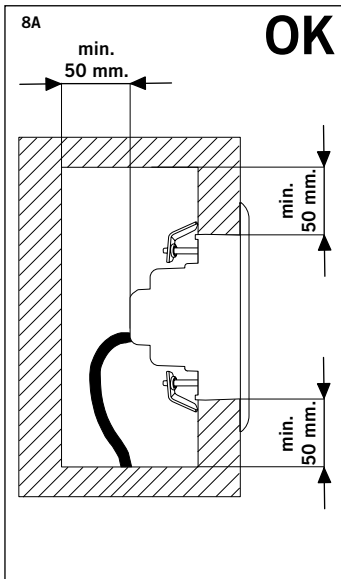
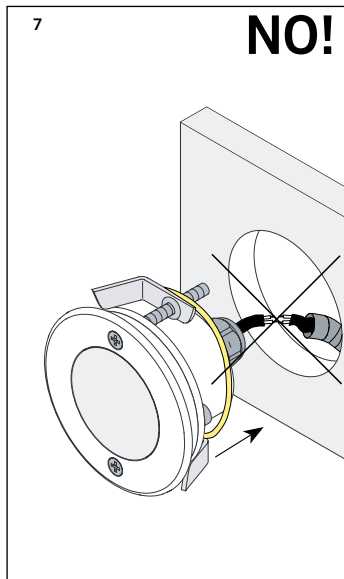

# CABLAGGIO WIRING

## Cablaggio solo per versione 24V Wiring only for 24V version

- 1. + Cavo Marrone  
Brown cable
- 2. - Cavo Blu  
Blue cable

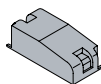
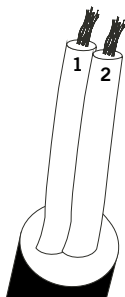

**ALIMENTATORE PER LED -  
VEDERE IL CATALOGO**

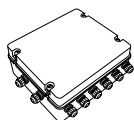

**POWER SUPPLY FOR LED  
- SEE CATALOGUE**

## Cablaggio solo per versione RGB 24V Wiring only for RGB 24V version

- 1. + Cavo Nero  
Black cable
- 2. R (Red) - Cavo Marrone  
Brown cable
- 3. G (Green) - Cavo Grigio  
Grey cable
- 4. B (Blue) - Cavo Blu  
Blue cable

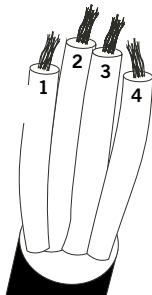

**S.3411**

**Gruppo di alimentazione e controllo  
RGB remoto. Per maggiori informa-  
zioni vedere le specifiche istruzioni E  
CATALOGO**

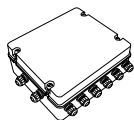

**RGB power supply and controller sepa-  
rate. For all specification please refer  
to the specific mounting sheet.**



## RACCOMANDAZIONI GENERALI PER LA MANUTENZIONE

Per tutti gli apparecchi di illuminazione al di là della classe di appartenenza e del tipo di utilizzo deve essere effettuata a cadenza programmata la manutenzione dell'installazione (norme CEI 64-8/6) che deve prevedere almeno le seguenti operazioni:

Pulire periodicamente gli apparecchi per rimuovere gli accumuli di sporco che si possono depositare sulle griglie e nella testa delle viti seguendo le ulteriori indicazioni riportate sulle istruzioni di montaggio allegate con ogni apparecchio.

Verificare il serraggio delle viti che fissano le varie parti dell'apparecchio (cornice vetro, vano di ingresso cavo, ecc.).

Verificare l'integrità di tutti i pressacavi e dei cavi. Verificare il serraggio dei pressacavi.

Per gli apparecchi in classe I verificare il serraggio del filo di terra all'apparecchio; il morsetto non deve presentare allentamento né ossidazione o danni di qualsiasi tipo. Se il caso serrare a fondo la vite del morsetto.

Per gli apparecchi in classe II verificare eventuali involucri plastici/isolanti, allo scopo di individuare eventuali danni agli isolamenti.

Verificare l'integrità e l'elasticità delle guarnizioni, che non devono risultare: Secche, Pizzicate, Interrotte o Danneggiate.

Verificare l'integrità dello schermo in vetro o plastico. Sostituirlo in caso di rottura o danneggiamento.

Verificare l'eventuale accumulo di acqua all'interno dell'apparecchio o della cassaforma.

I componenti interni come l'alimentatore, il trasformatore, la morsettiera, ecc. non devono presentare segni consistenti di ruggine o di ossidazione. La presenza di tali segnali indica una possibile penetrazione di acqua all'interno dell'apparecchio.

In caso di componenti danneggiati essi vanno sostituiti prima di rimettere in servizio l'apparecchio utilizzando solo ricambi originali.

Si consiglia di effettuare controlli ad ogni sostituzione di lampada o almeno ogni anno scegliendo il periodo più breve in relazione al tipo di impianto (Vedere anche Guida CEI 0-10 "Manutenzione degli impianti elettrici", Allegato C).

## GENERAL MAINTENANCE RECCOMENDATIONS

A scheduled maintenance programme must be carried out on the installation (norm CEI 64-8/6) and the fittings regardless of their IP rating or application – these must include the following operations:

Clean the fittings from dirt that may be deposited on the protection grills and in the heads of the screws by following the installation instructions attached to each fitting.

Check that the screws are not loose on the various components of the luminaire (glass frame, cable entry , ...).

Check each cable gland, and cable for damage and that the cable gland has not come loose.

For each Isolation Class 1 fitting check that the earth cable has not come loose. The clip must not show signs of oxidation, damage or become loose.

For class 2 fittings check any eventual plastic / isolating covering in order to verify any damage.

Check that all the seals are in good condition and that they are not dry, damaged or split.

Check the glass or plastic screen for damage and replace if required.

Check for water inside the luminaire's housing and its recessing box.

The internal components such as the ballasts, transformers, washers and screws must not show clear signs of oxidation or rust. Clear traces of rust and oxidation will indicate the presence of water inside the luminaire.

In case of damage the components must be replaced by original components and spare parts before using the fitting.

We also recommend to check the fitting each time the lamp is replaced or at least once a year or within the prescribed maintenance schedule period depending on the type of installation (Please see see guide CEI -10 Maintenance of electrical installations - attachment C).

## APPARECCHIO DI ILLUMINAZIONE INTERRATO CLASSE I

Questo tipo di apparecchio può essere soggetto a temporanee immersioni in acqua.

Dopo la **messa in servizio**, in caso di guasto o rottura, può verificarsi una riduzione del grado di **protezione IP** originale e l'infiltrazione di acqua; ne consegue una perdita di **protezione** di isolamento della carcassa metallica.

Pertanto e' **obbligatorio** che l'impianto elettrico preveda un **dispositivo di protezione** adeguato, interruttore differenziale o equivalente, che tolga tensione all'apparecchio in caso di guasto o rottura che determini un decadimento degli isolamenti, **in conformità alle norme impianti (CEI 64-8/4)** e **obbligatoriamente** ne venga verificata la sua piena efficienza a cadenza periodica.

L'intervento ripetuto di una protezione, sia esso di tipo magnetico-termico che differenziale o altro **deve** avviare una procedura per la ricerca del possibile guasto dell'impianto. E' assolutamente vietato by-passare le protezioni.

E' **obbligatorio** che l'installazione e la **messa in servizio** dell'apparecchio venga effettuata da **personale qualificato** nel rispetto delle norme impianti vigenti.

**Raccomandiamo** di valutare e verificare il luogo di installazione, il grado di usura a cui il prodotto può essere sottoposto e prevedere un adeguato piano di **manutenzione** dell'impianto elettrico e dell'apparecchio. Osservare eventuali regole impiantistiche vigenti per il tipo di impianto.

E' **vietato l'uso improprio** dell'apparecchio, ogni **manomissione** del prodotto o **modifica non autorizzata** dalla casa costruttrice **può causare serio danno a persone animali e cose**, e ne fa decadere ogni garanzia e responsabilità.

Per i prodotti in CLASSE I è inoltre **obbligatorio** il collegamento all'impianto di messa a terra.

## CLASS I INGROUND LUMINAIRES

This type of fitting can be subject to temporary submersion under water .

Damage or faults in the fitting **after its first installation** may lead to a reduction of the original **IP rating** and water infiltration therefore resulting in a loss of isolation **protection** of the metal housing.

It is therefore **compulsory** that the electrical system is provided with an adequate safety device, residual current operated circuit breaker, **in conformity to the norms**, that will cut off the circuit tension of the fitting in case of fault or breakdown that may cause a breakdown in the isolation, that must be in conformity to the norms (CEI 64-8/4) and whose efficiency must be verified on a regular basis.

The continuous cut off by the circuit breaker must lead to an inspection of the installation and electrical system in order to verify the fault. It is strictly forbidden to bypass any protection .

It is **compulsory** that the first installation is carried out by **qualified persons** in full conformity with the electrical system norms.

**We recommend** to evaluate and verify the place of installation and the level of use and wear that the fitting will be subject to and therefore provide for an adequate **maintenance** schedule of the electrical system and fittings. Please observe the norms relative to the type of installation or electrical system.

Any tampering or **improper use of the fitting is strictly forbidden**, any **modification without the specific written consent** of the manufacturer **can lead to serious damage and or injury to persons animals or objects**. In such event the manufacturer will not be held responsible or liable for any such damage or injury caused to persons animals or objects and declines any warranty claims.

For products in Class I it is **compulsory** to earth connect the fitting.

## ☐ APPARECCHIO DI ILLUMINAZIONE INTERRATO CLASSE II

Questo tipo di apparecchio può essere soggetto a temporanee immersioni in acqua.

Dopo la **messa in servizio**, in caso di rottura, può verificarsi una riduzione del grado di **protezione IP** originale e l'infiltrazione di acqua; ne consegue una perdita di **protezione** di isolamento della carcassa metallica.

Si ricorda che per i prodotti in CLASSE II **non è previsto** il collegamento all'impianto di messa a terra pertanto **si raccomanda** che l'impianto elettrico preveda **un dispositivo di protezione** adeguato, interruttore differenziale o equivalente **ad alta sensibilità**, che tolga tensione all'apparecchio in caso di guasto o rottura che determini un decadimento degli isolamenti, **in conformità alle norme impianti (CEI 64-8/4)** e **obbligatoriamente** ne venga verificata la sua piena efficienza a cadenza periodica.

L'intervento ripetuto di una protezione, sia esso di tipo magnetico-termico che differenziale o altro **deve** avviare una procedura per la ricerca del possibile guasto dell'impianto. E' assolutamente vietato by-passare le protezioni.

E' **obbligatorio** che l'installazione e la **messa in servizio** dell'apparecchio venga effettuata da **personale qualificato** nel rispetto delle norme impianti vigenti.

**Raccomandiamo** di valutare e verificare il luogo di installazione, il grado di usura a cui il prodotto può essere sottoposto e prevedere un adeguato piano di **manutenzione** dell'impianto elettrico e dell'apparecchio. Osservare eventuali regole impiantistiche vigenti per il tipo di impianto.

Per gli impianti pubblici riferirsi alle norme CEI 64-8/6, che prevedono anche verifiche strumentali dell'impianto e delle sue parti componenti. Tali norme stabiliscono che la cadenza dei controlli possa essere di qualche anno tranne che per gli impianti classificati come a maggior rischio (Ad esempio posti di lavoro, ai quali abbia accesso il pubblico).

E' **vietato l'uso improprio** dell'apparecchio, ogni **manomissione** del prodotto o **modifica non autorizzata** dalla casa costruttrice **può causare serio danno a persone animali e cose**, e ne fa decadere ogni garanzia e responsabilità.

## ☐ CLASS II INGROUND LUMINAIRES

This type of fitting can be subject to temporary submersion under water.

Faults in the fitting **after its first installation** may lead to a reduction of the original **IP rating** and water infiltration therefore resulting in a loss of isolation **protection** of the metal housing.

For CLASS II insulation rated fittings the earth connection is **not prescribed**, we therefore **recommend** that the electrical system is provided with an adequate **safety device**, residual current operated circuit breaker **with high sensitivity, in conformity to the norms**, that will cut off the circuit tension of the fitting in case of fault or breakdown that may cause a breakdown in the isolation, that must be in conformity to the norms ( CEI 64-8/4) and whose efficiency must be verified on a regular basis.

The continuous cut off by the circuit breaker must lead to an inspection of the installation and electrical system in order to verify the fault . It is strictly forbidden to bypass any protection.

It is **compulsory** that the first installation is carried out by **qualified persons** in full conformity with the electrical system norms.

**We recommend** to evaluate and verify the place of installation and the level of use and wear that the fitting will be subject to and therefore provide for an adequate **maintenance** schedule of the electrical system and fittings. . Please observe the norms relative to the type of installation or electrical system.

For public installations please refer to the norms (CEI 64-8/6) that also provide for testing of parts and components through technical instruments. Such norms specify that such tests may be carried out at yearly intervals with the exception of installations that have been classified as High Risk (for example workplace, or areas accessible to the public).

Any tampering or **improper use of the fitting is strictly forbidden**, any **modification without the specific written consent** of the manufacturer **can lead to serious damage and or injury to persons animals or objects**. In such event the manufacturer will not be held responsible or liable for any such damage or injury caused to persons animals or objects and declines any warranty claims.



I	<p><b>DIRETTIVA 2002/96/CE (Rifiuti di Apparecchiature Elettriche ed Elettroniche - RAEE): informazioni agli utenti</b></p> <p>L'etichetta con il cassonetto barrato presente sul prodotto indica che il prodotto non deve essere smaltito tramite la procedura normale di smaltimento dei rifiuti domestici. Per evitare eventuali danni all'ambiente e alla salute umana separare questo prodotto da altri rifiuti domestici in modo che possa venire riciclato in base alle procedure di rispetto ambientale. Per maggiori dettagli sui centri di raccolta disponibili, contattare l'ufficio governativo locale o il rivenditore del prodotto.</p>
GB	<p><b>Directive 2002/96/CE (Waste Electrical and Electronic Equipment - WEEE): information for users</b></p> <p>The crossed out wheeled bin label that can be found on your product indicates that this product should not be disposed of via the normal household waste stream. To prevent possible harm to the environment or human health please separate this product from other waste streams to ensure that it can be recycled in an environmentally sound manner. For more details on available collection facilities please contact your local government office or the retailer where you purchased this product.</p>
D	<p><b>Richtlinie 2002/96/EU (Elektro- und Elektronik- Altgeräte - WEEE): Benutzerinformationen</b></p> <p>Der Aufkleber mit durchgekreuzter Mülltonne an diesem Produkt weist darauf hin, dass dieses Produkt nicht im normalen Hausmüll entsorgt werden darf. Zur Vermeidung einer möglichen Beeinträchtigung der Umwelt oder der menschlichen Gesundheit darf dieses Produkt nicht in den Hausmüll gegeben werden, um zu gewährleisten, dass es in einer umweltverträglichen Weise recycelt wird. Wenden Sie sich für Informationen zu Entsorgungseinrichtungen an die zuständige Behörde oder das Geschäft, in dem Sie dieses Produkt erworben haben.</p>
F	<p><b>Directive 2002/96/CE (Déchets d'équipements électriques et électroniques - DEEE): informations aux utilisateurs</b></p> <p>L'étiquette apposée sur ce produit et représentant une poubelle à roulettes rayée indique que le produit ne peut être mis au rebut avec les déchets domestiques normaux. Afin d'éviter d'éventuels dommages au niveau de l'environnement ou de la vie humaine, veuillez séparer ce produit des autres déchets de manière à garantir qu'il soit recyclé de manière sûre au niveau environnemental. Pour plus de détails sur les sites de collecte existants, veuillez contacter l'administration locale ou le détaillant auprès duquel vous avez acheté ce produit.</p>
E	<p><b>Directiva 2002/96/CE (Residuos de aparatos eléctricos y electrónicos - RAEE): Información para el usuario</b></p> <p>La etiqueta de un contenedor tachado que hallará en su producto indica que este producto no se puede tirar con la basura doméstica normal. Para impedir posibles daños medioambientales o para la salud, separe este producto de otros canales de desecho para garantizar que se recicle de una forma segura para el medio ambiente. Para más información sobre las instalaciones de recolección disponibles, diríjase a las autoridades locales o al punto de venta donde adquirió este producto.</p>
SE	<p><b>Directive 2002/96/CE (Waste Electrical and Electronic Equipment - WEEE): information for users</b></p> <p>Symbolen med en överkorsad soptunna innebär att denna produkt inte får kastas i vanligt hushållsavfall. För att skydda miljön och hälsan bör denna produkt inte kastas tillsammans med vanligt hushållsavfall utan lämnas för återvinning på tillbörligt sätt. För mer information om uppsamlingsplatser, kontakta en lokal myndighet eller den återförsäljare som du köpte produkten från.</p>
NL	<p><b>Richtlijn 2002/96/EG (Afgedankte Elektrische en Elektronische Apparaten - AEEA): informatie voor de gebruikers</b></p> <p>Op uw product is een label van een rolcontainer met een kruis erdoor aangebracht. Dit wil zeggen dat dit product niet bij het normale huishoudelijk afval mag worden gedaan. Om eventuele schade aan het milieu of de gezondheid van de mens te voorkomen moet dit product gescheiden van al het ander afval worden ingezameld, zodat het op een verantwoorde wijze kan worden verwerkt. Voor meer informatie over uw lokale afvalinzameling wendt u zich tot uw gemeente of de leverancier bij wie u dit product hebt gekocht.</p>
PL	<p><b>Dyrektywa 2002/96/CE (WEEE - ang. Waste Electrical and Electronic Equipment): informacja dla użytkowników</b></p> <p>Użycie symbolu WEEE oznacza, że niniejszy produkt nie może być traktowany jako odpad domowy. Zapewniając prawidłową utylizację pomagasz chronić środowisko naturalne. W celu uzyskania bardziej szczegółowych informacji dotyczących recyklingu niniejszego produktu należy skontaktować się z przedstawicielem władz lokalnych, dostawcą usług utylizacji odpadów lub sklepem, gdzie nabyto produkt.</p>
FI	<p><b>Directive 2002/96/CE (Waste Electrical and Electronic Equipment - WEEE): information for users</b></p> <p>WEEE-merkintä osoittaa, että tätä tuotetta ei voi käsitellä kotitalousjätteen tavoin. Kun huoletdit tämän tuotteen asianmukaisesta hävittämisestä, autat suojelemaan ympäristöä. Lisätietoa tämän tuotteen kierrättämisestä saat paikallisviranomaisilta, jätehuoltoyhtiöltä tai myymälästä, josta osit tämän tuotteen.</p>
PT	<p><b>Directiva 2002/96/CE (Resíduos de equipamentos eléctricos e electrónicos - REEE): informações para os utilizadores</b></p> <p>A etiqueta com o símbolo de um contentor de lixo barrado com uma cruz que aparece no produto indica que este produto não deve ser deixado fora juntamente com o lixo doméstico. Para evitar possíveis danos no ambiente ou na saúde pública, por favor separe este produto de outros lixos; desta forma, terá a certeza de que pode ser reciclado através de métodos não prejudiciais ao ambiente. Para obter mais informações sobre os locais de recolha de lixo disponíveis, contacte a sua junta de freguesia ou o local onde comprou este produto.</p>
	<p> This information only applies to customers in the European Union, according to Directive 2002/96/EC OF THE EUROPEAN PARLIAMENT AND OF THE COUNCIL OF 27 January 2003 on waste electrical and electronic equipment (WEEE) and legislation transposing and implementing it into the various national legal systems.</p>



**SIMES S.p.A. VIA G. PASTORE 2/4 - 25040 CORTE FRANCA (BRESCIA) - ITALY**  
**TEL. +39 0309860430 - FAX +39 0309860439**  
**E-mail: [simes@simes.it](mailto:simes@simes.it) - <http://www.simes.it>**